

ASW3 SERIES

IN GROUND SWING DOOR OPERATOR

The Talbot ASW3 series represents the newest addition to our range of automatic door products. This concealed in-ground operator boasts an IP68 rating, ensuring durability and reliability. With the ability to operate in a full 180-degree arc, it optimizes people flow and enhances building access.



Key Features

- IP68 Rated floor box allows the ASW3 series to be installed on all external building doors.
- Compact and quiet operator capable of driving doors up to 150kg and 1200mm wide
- Obstruction sensitivity - if when opening or closing it meets an obstruction the doors will automatically re-open. When the power is off, the door is easily manually opened or closed.
- Compatible with a wide range of activation accessories including our accessible bathroom control switch.
- Compatible with all sorts of electronic locking including electric strikes, magnetic locks and drop pins.
- Slim form factor allows the ASW3 operator to easily replace a traditional hydraulic floor closer allowing us to retrofit existing pivot doors



Quality Componentry

Highly efficient long life and high torque brush-less DC motor alongside an intelligent microprocessor. that automatically detects door weight and adjusts accordingly to ensure smooth door operation.



Unparalleled safety

- Obstruction sensitivity
- wide range of safety detection sensor options available



180 Degree operation

The ASW3 Series operator can be configured to open in both directions allowing for seamless and intuitive people flow.

GET IN TOUCH

1300 560 608

sales@talbotautodoors.com.au
www.talbotautodoors.com.au

Unit 8, 63 Norman St
Peakhurst NSW, 2210

Technical Specifications

Power Voltage	AC 240v 50-60Hz
Motor	DC24v - 55w
Max door leaf weight	150Kg Per Leaf
Max door leaf width	1200mm
Opening Time	6- 12s Adjustable
opening Range	180 Degrees
Door hold open time	1 - 30s Adjustable
Noise	60Db or less
Working Temperature	-20C to +50c
Product Size	330mm x116mm x 100mm
Protection Level	IP68

Door Configurations

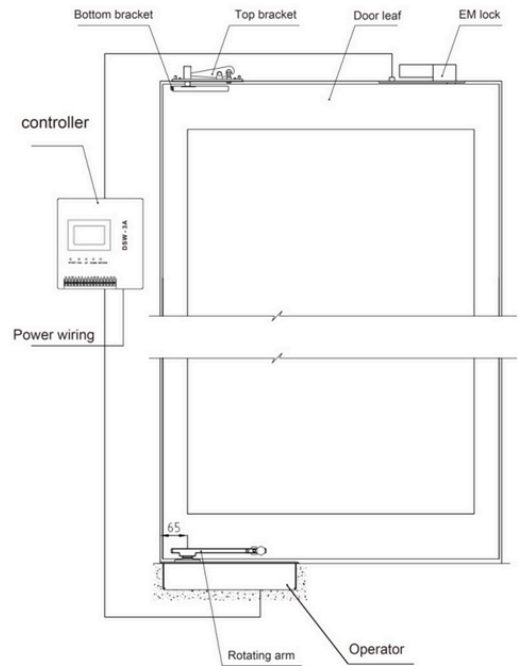

the ASW3A is designed for both aluminum framed and frame less glass door leaves up to 1200mm wide.

Operation modes:

- Auto - Sensor access inside and outside
- Open - Door hold open function
- Lock - Door locked



Projects

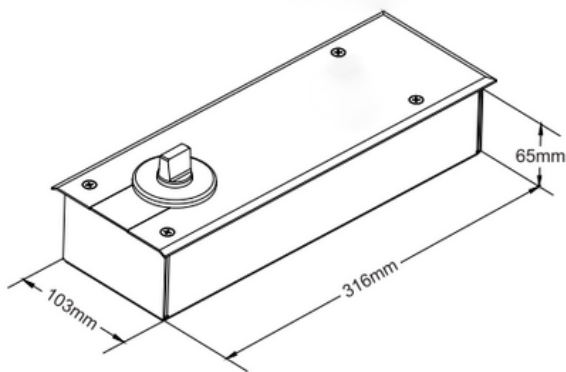

GET IN TOUCH

1300 560 608

sales@talbotautodoors.com.au
www.talbotautodoors.com.au

Unit 8, 63 Norman St
Peakhurst NSW, 2210